

# TSS SERIES CAM CLUTCH

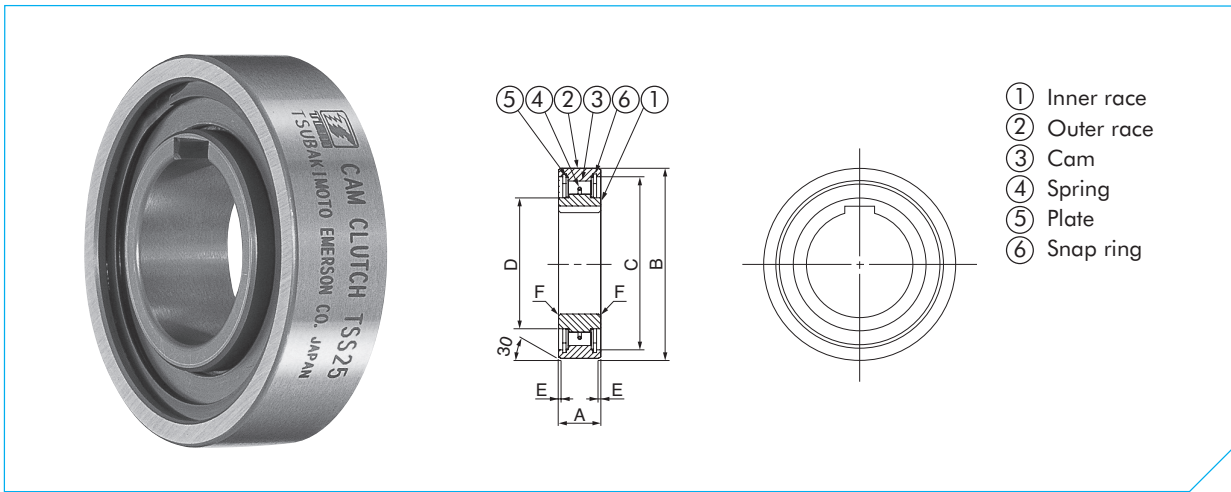

**TSS**

Dimensions in mm

Model	Torque Capacity Nm	Max. Overrunning Speed		Drag Torque Nm	Bore Size H7	Inner Race Keyway	A	B	C	D	E	F	Approx. Mass g/pc
		Inner Race r/min	Outer Race r/min										
TSS8	6.7	6000	3000	0.005	8	2 x 1.0	8	24	22.2	11.4	0.6	0.6	14
TSS10	12	4500	2300	0.007	10	3 x 1.4	9	30	27	15.6	0.6	0.6	27
TSS12	17	4000	2000	0.009	12	4 x 1.8	10	32	29.5	18	0.6	0.6	31
TSS15	22	3500	1800	0.01	15	5 x 1.2	11	35	32	20.6	0.6	0.6	39
TSS20	41	2600	1300	0.01	20	6 x 1.6	14	47	40	26.7	0.8	0.8	115
TSS25	56	2200	1100	0.02	25	8 x 2.0	15	52	45	32	0.8	0.8	140
TSS30	105	1800	900	0.03	30	8 x 2.0	16	62	55	40	0.8	1.0	215
TSS35	136	1600	800	0.03	35	10 x 2.4	17	72	63	45	0.8	1.0	300
TSS40	296	1400	700	0.18	40	12 x 2.2	18	80	72	50	0.8	1.0	425
TSS45	347	1300	650	0.21	45	14 x 2.1	19	85	75.5	57	1.2	1.0	495
TSS50	403	1200	600	0.22	50	14 x 2.1	20	90	82	62	1.2	1.0	545
TSS60	649	910	460	0.33	60	18 x 2.3	22	110	100	80	1.2	1.5	950

## Installation and Usage

1. TSS Series Clutches are designed for press fit installation. Correct interference dimensions must be maintained to obtain maximum clutch performance. The internal diameter of the housing should meet a H7 tolerance.
2. To avoid any radial force and when installing the clutch, the usage of a #62.. bearing is compulsory, since this clutch type does not have any bearing support.
3. Confirm the direction of rotation before installing.
4. The recommended shaft tolerance is h7 and the key profile should be in accordance with the following standards:  
TSS 8 ~ 12.....DIN6885.1  
TSS 15 ~ 60.....DIN6885.3
5. Suitable surface pressure of the key should be selected according to your company design standards.

## Lubrication

1. Oil lubrication is recommendable.
2. Never use oil or any other lubricant containing EP additives.

