

## Modello H-TA

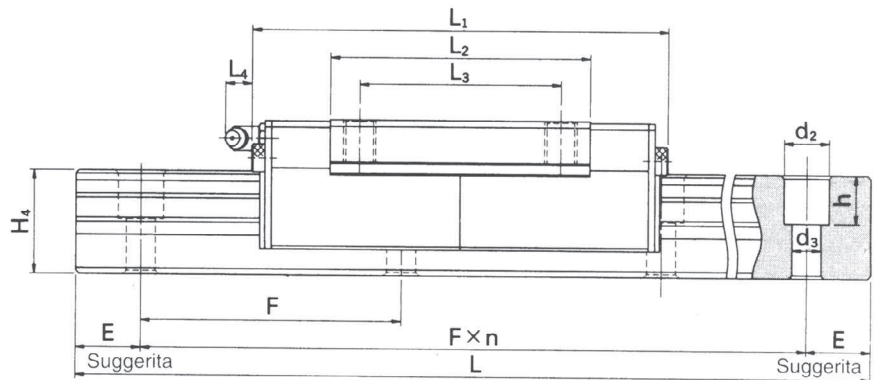
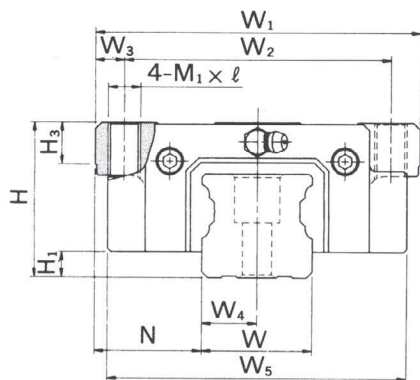

Modello	Dimensioni di montaggio			Dimensioni del cursore [mm]										Ingrassatore
	H	H <sub>1</sub>	N	W <sub>1</sub>	W <sub>2</sub>	W <sub>3</sub>	W <sub>5</sub>	L <sub>1</sub>	L <sub>2</sub>	L <sub>3</sub>	L <sub>4</sub>	H <sub>3</sub>	M <sub>1</sub> X ℓ	
<b>H15TA</b>	24	4.6	16	47	38	4.5	46.5	71	41	30	0	7	M 5 X 7	* vedi nota
<b>H20TA</b>	30	5	21.5	63	53	5	60	91	58	40	0	8	M 6 X 10	
<b>H25TA</b>	36	6.5	23.5	70	57	6.5	66	97	59	45	10	10	M 8 X 12	B-M6F
<b>H30TA</b>	42	7	31	90	72	9	81	111	68	52	10	13	M 10 X 14	B-M6F
<b>H35TA</b>	48	8	33	100	82	9	92	128	80	62	10	13	M 10 X 16	B-M6F
<b>H45TA</b>	60	11	37.5	120	100	10	112	158	102	80	12	15	M 12 X 19	B-PT1/8
<b>H55TA</b>	70	14	43.5	140	116	12	130	189	124	95	12	17	M 14 X 23	B-PT1/8
<b>H65TA</b>	85	14	53.5	170	142	14	162	225	148	110	12	20	M 16 X 29	B-PT1/8
<b>H65TAH</b>	90	14	53.5	170	142	14	162	225	148	110	12	20	M 16 X 29	B-PT1/8

### \* NOTA

- I cursori normalmente presentano un foro  $\varnothing 3.3$  profondo 3 [mm].
- A richiesta, si possono fornire separatamente gli ingrassatori (mod. NAS516-1A).

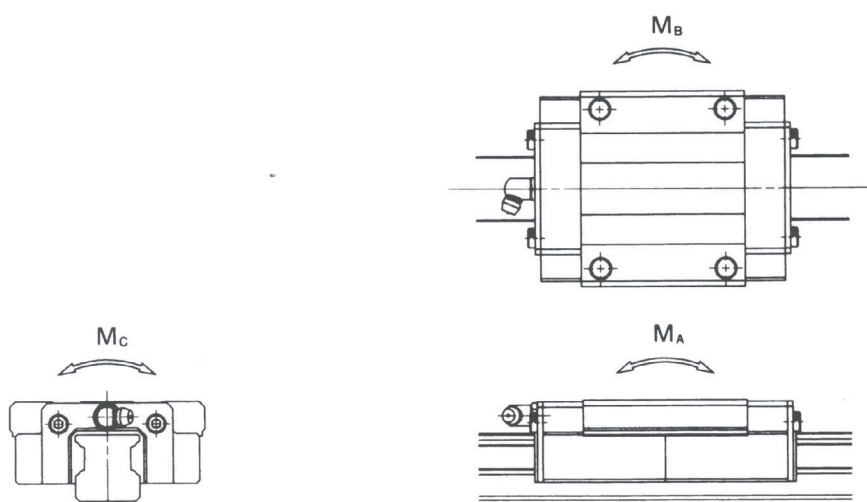

Dimensioni del binario [mm]								Capacità di carico nominale kgf		Coppia statica nominale kgf•m			Peso		Modello
W	W <sub>4</sub>	H <sub>4</sub>	d <sub>2</sub>	d <sub>3</sub>	h	E	F	C	C <sub>o</sub>	M <sub>A</sub>	M <sub>B</sub>	M <sub>C</sub>	corsore kgf	binario kgf/m	
15	7.5	17	7.5	4.5	7	29	60	860	1380	7	7	13	0.21	1.7	<b>H15TA</b>
20	10	21	9.5	6	11	29	60	1420	2430	16	16	27	0.4	2.8	<b>H20TA</b>
23	11.5	24	11	7	11	29	60	2040	3510	28	28	45	0.64	3.7	<b>H25TA</b>
28	14	28	14	9	14	39	80	2880	4780	44	44	73	1.0	5.3	<b>H30TA</b>
34	17	32	14	9	15	39	80	3830	6380	65	65	115	1.5	7.5	<b>H35TA</b>
45	22.5	42	20	14	21	52	105	6140	9760	133	133	235	2.7	12.9	<b>H45TA</b>
53	26.5	48	23	16	24	59	120	9180	13980	226	226	434	4.4	17.3	<b>H55TA</b>
63	31.5	58	26	18	25	74	150	14390	21940	429	429	753	8.4	24.9	<b>H65TA</b>
63	31.5	58	26	18	25	74	150	14390	21940	429	429	753	8.4	24.9	<b>H65TAH</b>

Binario disponibile con trattamento RAYDENT.