

# **TSUBAKI EMERSON CAM CLUTCH BR-HT SERIES**

***BACKSTOP CAM CLUTCH  
For High-Speed Overrunning***

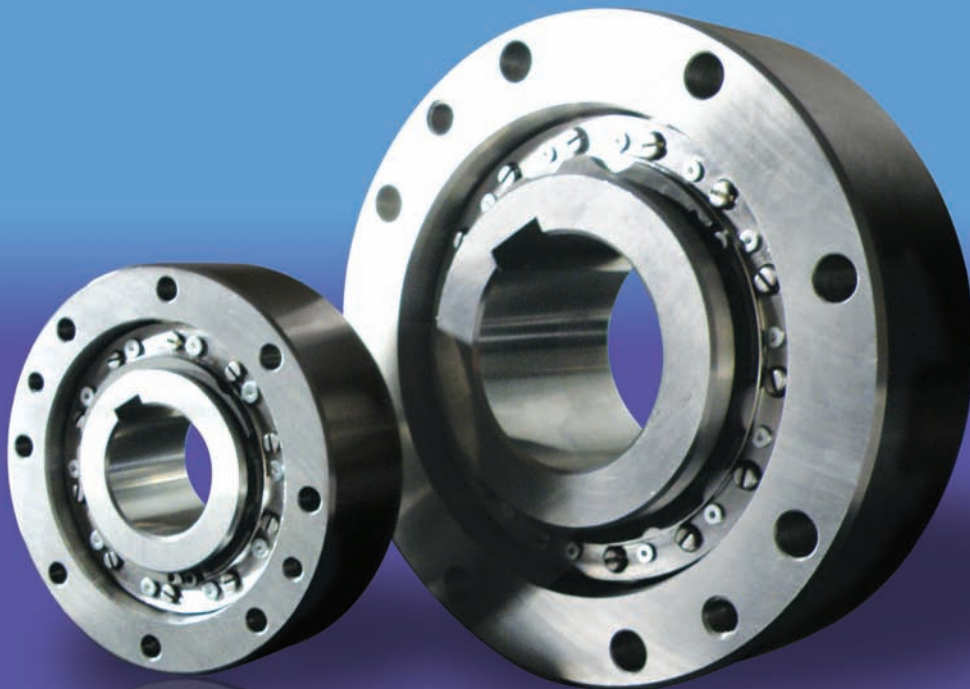

***Higher Torque and Longer Life  
"LIFT OFF TYPE"***

# BACKSTOP TO PREVENT REVERSE ROTATION

BR-HT Cam Clutch is High Torque version of existing BR series.  
 BR-HT is mainly used in backstop application for the inner race high-speed overrunning.  
 Prevention of reverse rotation for inclined conveyor and bucket elevator are typical application examples.  
 BR-HT assures not only the immediate backstop function under the high torque, but also the long service life by the "Lift-Off" design.  
 In addition installation on the high speed shaft with low torque enables selection of more compact models with resulting lower cost.  
 We can offer the most appropriate model from wide range of size according to your needs.

## Non-contact design extends service life

### Greatly Increased Service Life

Made possible by TSUBAKI's extensive experience in mechanical power transmission, the cam used in BR-HT Cam Clutch offers a unique cross section that provides positive mechanical engagement only when needed. Otherwise, the Cam Clutch rotates freely with absolutely no mechanical contact in the clutch mechanism. The result is a greatly increased service life compared to conventional types.

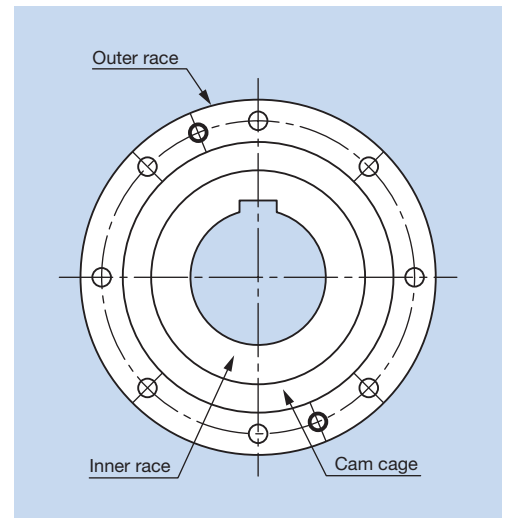
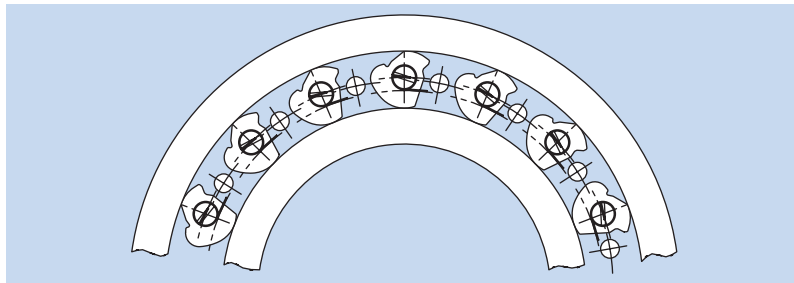

### Backstop applications for high-speed overrunning

When the Cam Clutch is stationary, the cam locks the inner and outer races together. When the inner race (load side) overruns at a high speed, the cam disengages by releasing from the inner race (figure 1). When the inner race stops, the cam rotates back into an engaged position. If the inner race tries to rotate in the reverse direction, the cams then serve as prop between the anchored outer race and inner race to prevent the reverse rotation and provide backstopping.

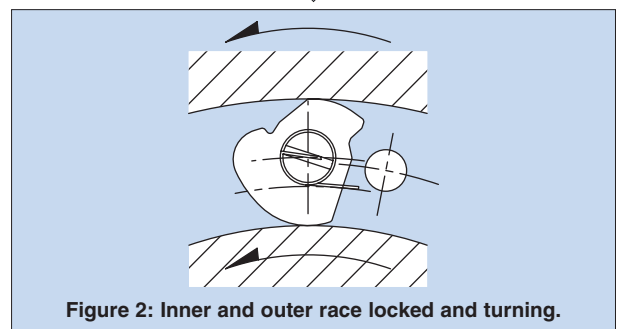
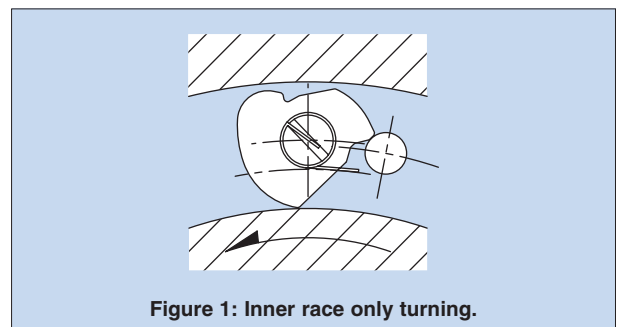

### A more economical design

BR-HT series features a simple design in which the Cam Clutch mechanism is incorporated in a cage between standard dimension inner and outer bearing races. This allows the Cam Clutch to be easily and economically integrated into a wide variety of mechanical systems.

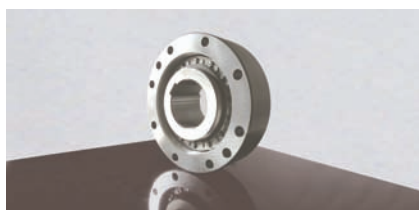

### Table of Contents

Feature/Application .....	1
Selection/Service life .....	2
Dimensions & Capacities .....	3-4
Installation & Usage .....	5
Keyway .....	6

## TYPICAL APPLICATION

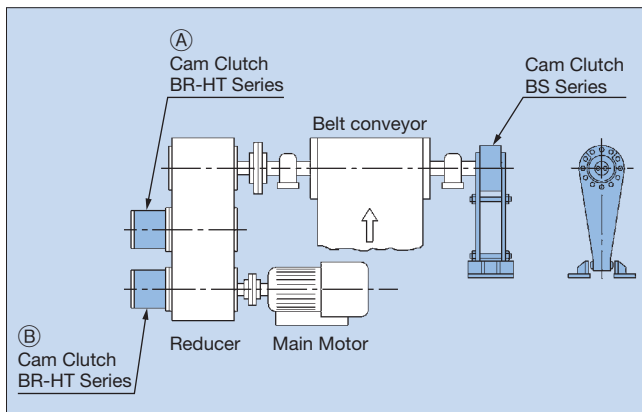

### Mounting position (A)

Intermediate shaft of Reducer

Use: Backstop for medium speed overrunning

### Mounting position (B)

Input shaft of Reducer

Use: Backstop for high-speed overrunning

Other application

- Pump Backstopping
- Fan Backstopping
- Backstopping function in high speed inner race overrunning

## SELECTION PROCEDURES

### For Back Stop Application

Calculate the torque on the Cam Clutch according to the following formula:

$$T = \frac{9550 \times P}{N} \times SF$$

T: Loaded torque (N·m)

P: Nominal torque of Motor (kW)

N: Shaft speed (r/min)

SF: Service factor

- Notes:**
1. SF 1.6 (Service condition: For belt conveyor or bucket elevator)
  2. Select the clutch whose T.C. satisfies the calculated backstop torque (T).
  3. If there is a chance of motor stall, include the stall torque ratio in your calculations.

Select Clutch by:

- a) Design torque requirement and service factor
- b) The actual overrunning speed should be between MIN r/min and MAX r/min
- c) Bore

In case the overrunning speed is less than MIN r/min or higher than MAX r/min, please contact TSUBAKI.

## SERVICE LIFE OF BR-HT SERIES

The service life of previous TSUBAKI Cam Clutch was determined as the frictional service life during free-running (clutch disengaged) and the fatigue service life of the engaged clutch. However, with BR-HT Series, free-running frictional service life is not a factor because there is no mechanical contact when the clutch is disengaged. As a result, service life is determined solely by the fatigue life of the engaged clutch.

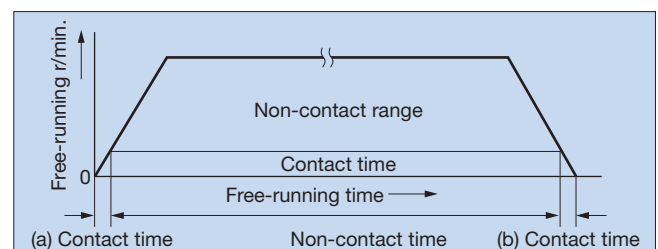

Friction in the clutch mechanism only occurs during a very short period of time denoted by "a" and "b". "a" is the time during which the cam is engaged until the acceleration of inner race causes it to disengage. "b" is the time during which the cam engages when the inner race decelerates.

# BR-HT SERIES CAM CLUTCH

## MODELS BR15HT TO BR130HT

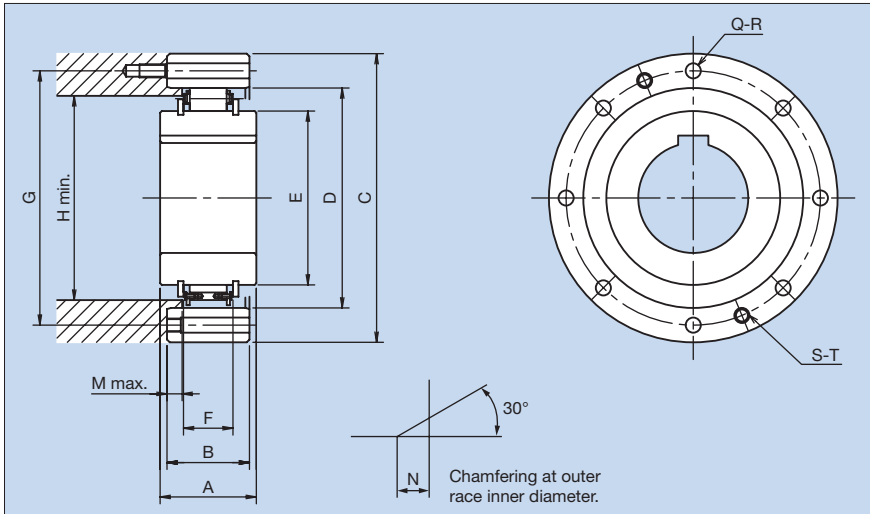

### Format

**BR40HT - R66B - 35**

Bore size

Size & Length of cam  
A, B, C, D type  
WA/WB/WC/WD type  
(W=Double cam cage)

Model name  
HT=High Torque

## Dimensions and Capacities

Dimensions in mm

Model	Bore Size (H7)	T.C. (N·m)	Inner Race Overrunning Speed (r/min)		Max. Engagement (r/min)	A	B	C	D (H7)	E	Mounting Holes		Removal Holes		F	Min. Mass (kg)	Max. Mass (kg)	H min.	M max.	Chamfer N
			Min.	Max.							PCD G	Q'ty-Size Q-R	Q'ty-Size S-T							
BR15HT-R31A	*20	105	880	3,600	550	24	25	85	55	30	70	6-M6	2-M6	17.0	—	0.8	45	3	1	
BR18HT-R38A	*25	155	850	3,600	500	24	25	90	62	37	75	6-M6	2-M6	17.0	—	0.9	50	3	1	
BR20HT-S20B	20	225	850	3,600	400	35	35	90	66	41	78	6-M6	2-M6	25.0	—	1.3	53	4	1	
BR25HT-B46B	25 30	400	800	3,600	380	35	35	95	70	45	82	6-M6	2-M6	25.0	1.4	1.4	58	4	1	
BR30HT-S30B	30	500	740	3,600	360	35	35	100	75	50	87	6-M6	2-M6	25.0	—	1.5	64	4	1	
BR30HT-R51B	25 30 35 36	500	740	3,600	360	35	35	105	75	50	90	6-M6	2-M6	25.0	1.7	1.8	64	4	1	
BR35HT-B56B	35 40	600	710	3,600	340	35	35	110	80	55	96	8-M6	2-M6	25.0	1.8	1.9	70	4	1	
BR38HT-R61A	30 35 40 *45	425	740	3,600	400	25	25	120	85	60	105	6-M8	2-M8	19.0	1.6	1.8	74	3	1	
BR40HT-S40B	40	850	670	3,600	320	35	35	125	90	65	108	8-M8	2-M8	25.0	—	2.4	82	4	1	
BR40HT-R66B	35 40 45 *48	850	670	3,600	320	35	35	132	90	65	115	8-M8	2-M8	25.0	2.7	2.9	82	4	1	
BR35HT-S45B	45	950	640	3,600	310	35	35	130	95	70	112	8-M8	2-M8	25.0	—	2.6	86	4	1	
BR48HT-R76B	45 55 *60	1,100	620	3,600	300	35	35	140	100	75	125	8-M8	2-M8	25.0	2.9	3.3	92	4	1	
BR50HT-B86B	40 45 50 60 65 *70	1,450	590	3,600	280	40	40	150	110	85	132	8-M8	2-M8	25.0	3.5	4.3	103	6.5	1	
BR58HT-R101B	55 70 *80	1,800	550	3,600	260	50	50	175	125	100	155	8-M10	2-M10	25.0	5.8	6.7	117	11.5	1	
BR60HT-B85A	45 50 60 65	2,400	420	3,600	230	60	50	175	125	92	155	8-M10	2-M10	36.0	6.8	7.6	110	6	1	
BR70HT-B100A	45 50 55 60 70 75 *80	3,150	390	3,600	220	60	50	190	140	107	165	12-M10	2-M10	36.0	7.6	9.2	125	6	1.5	
BR80HT-S80A	80	5,000	440	3,600	200	70	60	210	160	127	185	12-M10	2-M10	36.0	—	12	148	11	1.5	
BR80HT-B120B	60 65 70 75 80 95	7,000	310	3,600	160	70	60	210	160	127	185	12-M10	2-M10	50.0	11	13	148	4	1.5	
BR90HT-S90A	90	6,000	410	3,000	190	80	70	230	180	147	206	12-M12	2-M12	36.0	—	16	170	16	2	
BR90HT-B140B	65 90 100 110	9,000	300	3,000	150	70	70	245	180	147	218	12-M12	2-M12	50.0	17	20	170	9	2	
BR95HT-S100C	100	20,500	240	2,700	130	90	80	290	210	177	258	12-M16	2-M16	63.0	—	33	200	7.5	2	
BR95HT-R170C	70 85 90 100 120 130	20,500	240	2,700	130	80	80	290	210	177	258	12-M16	2-M16	63.0	29	35	200	7.5	2	
BR98HT-R200C	130 155	27,000	230	2,100	110	80	80	310	240	207	278	12-M16	2-M16	63.0	30	33	230	7.5	2	
BR100HT-S100A	100	11,000	440	2,700	210	90	80	290	210	143	258	12-M16	2-M16	52.6	—	28	200	11.5	2	
BR130HT-S130A	130	16,000	400	2,400	190	80	80	322	240	173	278	12-M16	2-M16	52.6	—	33	210	11.5	2	

### Notes: 1. T.C...Torque Capacity

The maximum transmissible torque is twice the T.C.

2. Keyway No Mark on Bore Size...ISOR773/DIN6885.1

\*Mark on Bore Size...DIN6885.3

3. Min. overrunning speed of inner race should not be below under continuous operation.

4. Max. engagement speed must not be exceeded when transmitting torque.

## Recommended Cover Dimension Table

Dimensions in mm

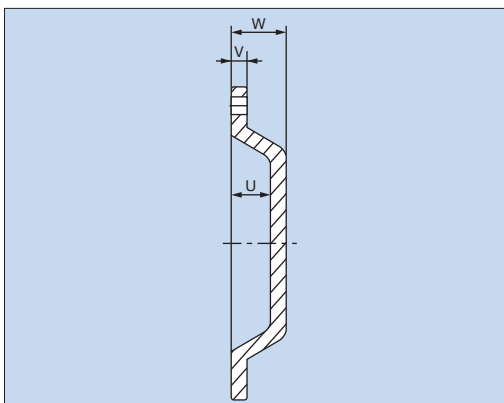

BR-HT Size	Width		Depth
	W	V	U
BR15HT to BR38HT	21	8	15
BR40HT to BR50HT	23	11	17
BR58HT to BR60HT	28	11	22
BR70HT to BR95HT-S100C	35	11	29
BR95HT-R170C to BR130HT	42	15	33
BR180HT	60	15	48
BR190HT to BR230HT	60	18	48
BR240HT to BR300HT	68	26	56

# BR-HT SERIES CAM CLUTCH

## MODELS BR180HT TO BR300HT

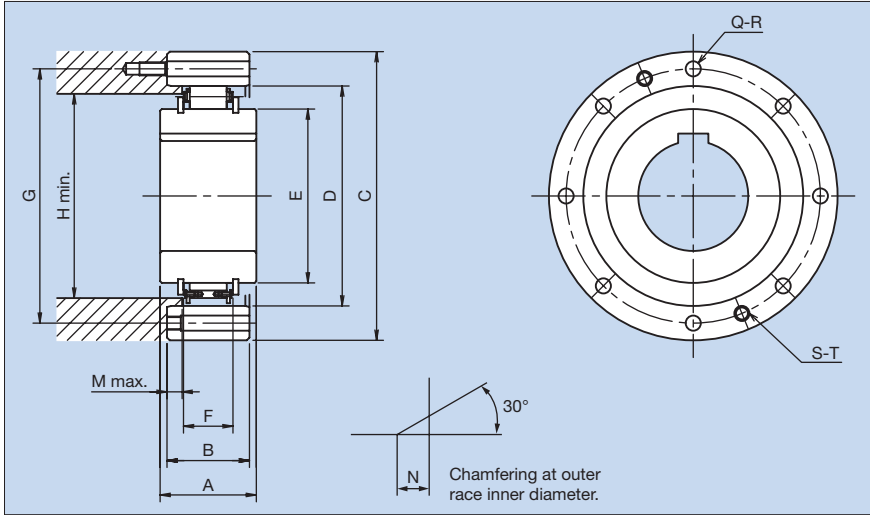

### Format

**BR40HT - R66B - 35**

Bore size

Size & Length of cam  
A, B, C, D type  
WA/WB/WC/WD type  
(W=Double cam cage)

Model name  
HT=High Torque

## Dimensions and Capacities

Dimensions in mm

Model	Bore Size (H7)	T.C. (N·m)	Inner Race Overrunning Speed (r/min)		Max. Engagement (r/min)	A	B	C	D (H7)	E	Mounting Holes		Removal Holes		F	Mass (kg)	H min.	M max.	Chamfer N
			Min.	Max.							PCD G	Q'ty-Size Q-R	Q'ty-Size S-T						
BR180HT-S180A	180	32,000	300	1,300	160	90	80	412	310	243	360	12-M20	2-M20	53	56	280	11.5	2	
BR180HT-S180C	180	53,000	250	1,300	120	120	120	422	310	243	370	16-M20	2-M20	83	85	280	16.5	2	
BR180HT-S180WA	180	64,000	300	1,300	160	160	160	412	310	243	360	12-M20	2-M20	106	107	280	30	2	
BR180HT-S180WC	180	106,000	250	1,300	120	240	240	425	310	243	370	16-M20	2-M20	166	174	280	35	2	
BR180HT-R240A	185	32,000	220	1,300	110	90	80	400	310	243	360	12-M20	2-M20	53	50	280	11.5	2	
BR180HT-R240D	185	64,000	210	1,300	100	120	125	420	310	243	370	16-M24	2-M24	96	84	280	12.5	2	
BR180HT-R240WB	185	70,000	220	1,300	110	160	160	412	310	243	360	24-M20	2-M20	140	100	280	8	2	
BR180HT-R240WD	185	128,000	210	1,300	100	240	240	425	310	243	370	24-M24	2-M24	192	163	280	22	2	
BR190HT-R260A	205	39,000	200	1,300	95	105	80	430	330	263	380	16-M20	2-M20	53	60	300	11.5	2	
BR220HT-S220A	220	45,000	280	1,100	140	105	80	470	360	293	410	16-M20	2-M20	53	74	330	11.5	2	
BR220HT-S220C	220	70,000	230	1,100	110	120	120	470	360	293	410	24-M20	2-M20	83	100	330	16.5	2	
BR220HT-S220WA	220	90,000	280	1,100	140	160	160	480	360	293	410	18-M24	2-M24	106	141	330	25	2	
BR220HT-S220WC	220	140,000	230	1,100	110	240	240	490	360	293	410	20-M30	2-M30	166	215	330	35	2	
BR220HT-R290B	230	60,000	195	1,100	115	105	80	460	360	293	410	16-M20	2-M20	70	87	330	3	2	
BR220HT-R290D	230	92,000	190	1,100	95	120	110	460	360	293	410	16-M20	2-M20	96	146	330	5	2	
BR220HT-R290WB	230	120,000	195	1,100	115	160	160	480	360	293	410	18-M24	2-M24	140	120	330	8	2	
BR220HT-R290WD	230	184,000	190	1,100	95	240	240	490	360	293	425	20-M30	2-M30	192	206	330	22	2	
BR230HT-R310B	240	70,000	190	1,100	90	110	125	497	380	313	450	24-M20	2-M20	70	110	350	25.5	3	
BR230HT-R310D	240	110,000	185	1,100	80	120	125	497	380	313	450	24-M20	2-M20	96	116	350	12.5	3	
BR240HT-S240A	240	54,000	220	1,100	120	105	90	500	390	323	440	16-M20	2-M20	53	91	360	16.5	3	
BR240HT-S240C	240	88,000	185	1,100	110	120	120	520	390	323	440	16-M24	2-M24	83	129	360	16.5	3	
BR240HT-S240WA	240	108,000	220	1,100	120	180	180	505	390	323	440	24-M24	2-M24	106	161	360	35	3	
BR240HT-S240WC	240	176,000	185	1,100	110	240	240	530	390	323	440	24-M30	2-M30	166	249	360	35	3	
BR240HT-R320B	250	77,000	190	1,100	115	105	80	490	390	323	440	16-M24	2-M24	70	78	360	3	3	
BR240HT-R320D	250	113,000	180	1,100	105	120	120	520	390	323	440	16-M24	2-M24	96	128	360	10	3	
BR240HT-R320WB	250	154,000	190	1,100	115	180	180	505	390	323	440	24-M24	2-M24	140	173	360	18	3	
BR240HT-R320WD	250	226,000	180	1,100	105	240	240	530	390	323	460	24-M30	2-M30	192	259	360	22	3	
BR260HT-S260A	260	66,000	250	1,000	130	105	105	550	430	363	500	16-M24	2-M24	57	122	400	22	3	
BR260HT-S260C	260	110,000	190	1,000	100	125	125	580	430	363	500	24-M24	2-M24	87	170	400	17	3	
BR260HT-S260WA	260	132,000	250	1,000	130	210	210	550	430	363	500	24-M24	2-M24	114	235	400	46	3	
BR260HT-S260WC	260	220,000	190	1,000	100	250	250	580	430	363	500	24-M30	2-M30	174	323	400	36	3	
BR260HT-R360D	280	150,000	170	1,000	90	125	120	540	430	363	500	24-M24	2-M24	100	127	400	8	3	
BR260HT-R360WB	280	196,000	175	1,000	95	210	210	550	430	363	500	24-M24	2-M24	148	227	400	29	3	
BR260HT-R360WD	280	300,000	170	1,000	90	250	250	580	430	363	500	24-M30	2-M30	200	311	400	23	3	
BR300HT-S300A	300	82,000	230	1,000	120	105	105	630	480	413	560	24-M24	2-M24	53	163	460	22	3	
BR300HT-S300C	300	140,000	200	1,000	95	125	125	630	480	413	560	24-M24	2-M24	83	198	460	17	3	
BR300HT-S300WA	300	164,000	230	1,000	120	210	210	630	480	413	560	24-M24	2-M24	106	324	460	46	3	
BR300HT-R410D	320	195,000	165	1,000	85	125	120	630	480	413	560	24-M24	2-M24	100	186	460	8	3	
BR300HT-R410WB	320	250,000	165	1,000	85	210	210	630	480	413	560	24-M24	2-M24	148	314	460	29	3	
BR300HT-R410WD	320	366,000	165	1,000	85	220	220	630	480	413	560	24-M30	2-M30	200	324	460	8	3	

### Notes:

1. T.C.---Torque Capacity  
The maximum transmissible torque is twice the T.C.
2. Keyway No Mark on Bore Size...ISOR773 DIN6885.1
3. Min. overrunning speed of inner race should not be below under continuous operation.
4. Max. engagement speed must not be exceeded when transmitting torque.



# BR-HT SERIES CAM CLUTCH

## INSTALLATION AND USAGE

While the Cam Clutch can be disassembled by the user, reassembly may prove difficult. We recommend that you install the Cam Clutch as delivered.

There are removal hole at the end face of the outer race. Install the Cam Clutch so that it comes to the installation face.

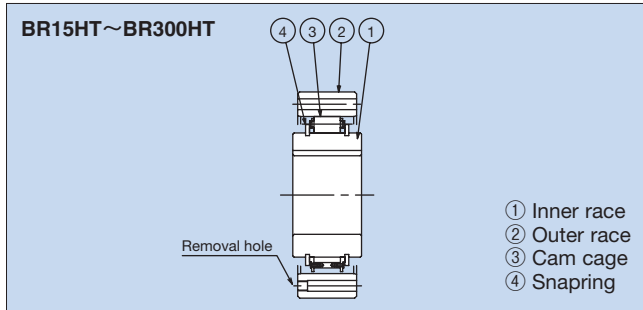

### Installation and Usage

- We recommend using shaft tolerances of h6 or h7 for Cam Clutch installation.
- Use ISO R773/DIN 6885.1 Parallel key or DIN6885.3 Parallel key for models marked\* on page 3. Ensure that the key does not move in the keyway. A loose key will damage the Cam Clutch.
- When installing the Cam Clutch over a shaft, please follow the procedure outlined below. Never strike the clutch with a steel hammer or apply unnecessary impact loads.
  - Verify Cam Clutch direction of rotation. The arrow on the inner race shows the free running (cam disengaged) direction. Make sure that the direction of cam engagement matches the intended application.
  - Tap the inner race lightly with a soft hammer moving around the race circumference so the Cam Clutch moves slowly and uniformly onto the end of the shaft. Make sure that the outer race does not become dislodged.
  - Place an end plate over the inner race and use the mounting bolts to pull the Cam Clutch onto the shaft as shown in Installation Method at right.
  - Fix the end plate securely.
- If you are installing the outer race first, check the precision of the fit. The tolerances for outer race mounting are shown in the tables at right. Verify that the correct tolerances can be obtained. Out of spec installation could damage the Cam Clutch.
- Non-lubricated when shipping please lubricate before use. To lubricate the Cam Clutch, apply lubricant at the outer circumference of the inner race (see Typical Installation 1). Avoid over lubrication, as it will cause the Cam Clutch to generate excessive heat.
- BR-HT Series accept lubricant generally used in gear reducer. It is possible to mount BR-HT directly in gearbox without separate lubrication.
- When installing a cover or seal support over the outer race, use bolts with a tensile rating of 10.9 or greater. Use a sealing agent or packing material between the mating services to prevent leakage.

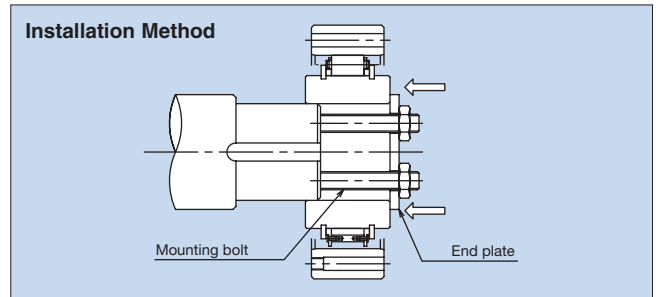
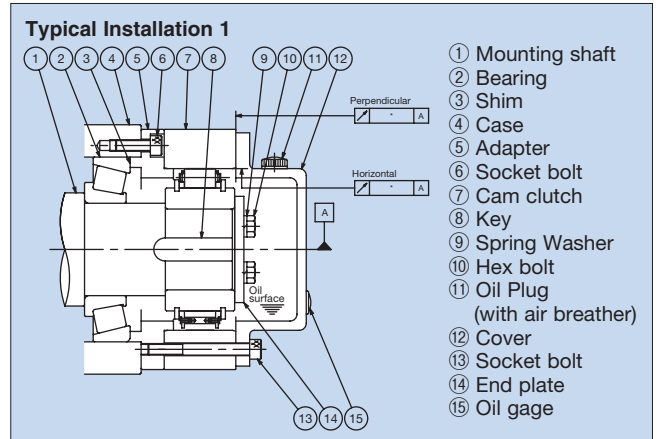

### Parallel Tolerances

Dimensions in mm	
Model	Parallelism
BR15HT to BR58HT	0.10
BR60HT to BR98HT	0.15
BR100HT and above	0.25

### Right Angle Tolerances

Dimensions in mm	
Model	Angularity
BR15HT to BR58HT	0.04
BR60HT to BR98HT	0.06
BR100HT and above	0.08

## LUBRICATION FOR THE BR-HT SERIES

BR-HT Series Cam Clutch needs periodic maintenance and lubrication to provide maximum performance throughout their service life. Lack of the prescribed maintenance and lubrication will shorten the Cam Clutch's service life and may result in unnecessary mechanical damage. BR-HT Cam Clutch can be lubricated with oil or depending on the type of application.

### 1. Recommended Oil

Brand	Type
Nippon oil	FBK Turbine 32, Pantorque Dexron
Shell	Rotera 10W, Rimura 10W, Turbo Oil T32
Mobil	DTE Oil Light, ATF 220
Esso	Teresso 32, Dexron II

- The above oils are recommended for operating environments ranging from -5°C to +40°C. Contact TSUBAKI when the environmental temperature is out of this range.
- Special Cam Clutch oil (1 litre can) is available from TSUBAKI.

# KEYWAY DIMENSION

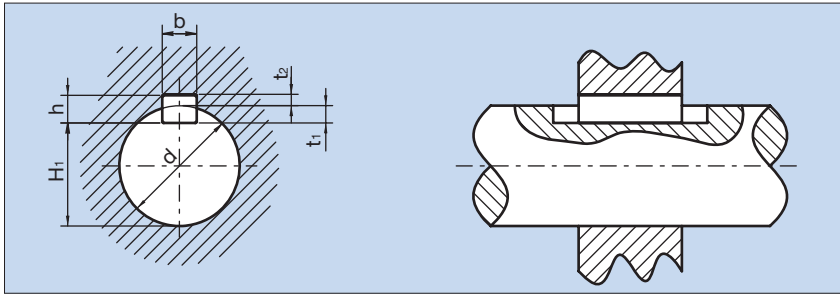

Dimensions in mm

Key b×h	Corresponding shaft dimension d	Din 6885.1				DIN 6885.3			
		Keyway dimension for bores		Keyway dimension for shafts		Keyway dimension for bores		Keyway dimension for shafts	
		b	t <sub>2</sub>	t <sub>1</sub>	H <sub>1</sub>	b	t <sub>2</sub>	t <sub>1</sub>	H <sub>1</sub>
6×6	over 17 incl. 22	6	2.8	3.5	$\begin{smallmatrix} 0 \\ -0.1 \end{smallmatrix}$	6	1.5	2.5	$\begin{smallmatrix} 0 \\ -0.1 \end{smallmatrix}$
8×7	over 22 incl. 30	8	3.3	4.0	$\begin{smallmatrix} 0 \\ -0.2 \end{smallmatrix}$	8	2	3.1	$\begin{smallmatrix} 0 \\ -0.2 \end{smallmatrix}$
10×8	over 30 incl. 38	10	3.3	5.0	$\begin{smallmatrix} 0 \\ -0.2 \end{smallmatrix}$	10	2.4	3.7	$\begin{smallmatrix} 0 \\ -0.2 \end{smallmatrix}$
12×8	over 38 incl. 44	12	3.3	5.0	$\begin{smallmatrix} 0 \\ -0.2 \end{smallmatrix}$	12	2.2	3.9	$\begin{smallmatrix} 0 \\ -0.2 \end{smallmatrix}$
14×9	over 44 incl. 50	14	3.8	5.5	$\begin{smallmatrix} 0 \\ -0.2 \end{smallmatrix}$	14	2.1	4	$\begin{smallmatrix} 0 \\ -0.2 \end{smallmatrix}$
16×10	over 50 incl. 58	16	4.3	6.0	$\begin{smallmatrix} 0 \\ -0.2 \end{smallmatrix}$	16	2.4	4.7	$\begin{smallmatrix} 0 \\ -0.2 \end{smallmatrix}$
18×11	over 58 incl. 65	18	4.4	7.0	$\begin{smallmatrix} 0 \\ -0.2 \end{smallmatrix}$	18	2.3	4.8	$\begin{smallmatrix} 0 \\ -0.2 \end{smallmatrix}$
20×12	over 65 incl. 75	20	4.9	7.5	$\begin{smallmatrix} 0 \\ -0.2 \end{smallmatrix}$	20	2.7	5.4	$\begin{smallmatrix} 0 \\ -0.2 \end{smallmatrix}$
22×14	over 75 incl. 85	22	5.4	9.0	$\begin{smallmatrix} 0 \\ -0.2 \end{smallmatrix}$	22	3.1	6	$\begin{smallmatrix} 0 \\ -0.2 \end{smallmatrix}$
25×14	over 85 incl. 95	25	5.4	9.0	$\begin{smallmatrix} 0 \\ -0.2 \end{smallmatrix}$	25	2.9	6.2	$\begin{smallmatrix} 0 \\ -0.2 \end{smallmatrix}$
28×16	over 95 incl. 110	28	6.4	10.0	$\begin{smallmatrix} 0 \\ -0.2 \end{smallmatrix}$	28	3.2	6.9	$\begin{smallmatrix} 0 \\ -0.2 \end{smallmatrix}$
32×18	over 110 incl. 130	32	7.4	11.0	$\begin{smallmatrix} 0 \\ -0.2 \end{smallmatrix}$	32	3.5	7.6	$\begin{smallmatrix} 0 \\ -0.2 \end{smallmatrix}$
36×20	over 130 incl. 150	36	8.4	12.0	$\begin{smallmatrix} 0 \\ -0.3 \end{smallmatrix}$	36	3.8	8.3	$\begin{smallmatrix} 0 \\ -0.2 \end{smallmatrix}$
40×22	over 150 incl. 170	40	9.4	13.0	$\begin{smallmatrix} 0 \\ -0.3 \end{smallmatrix}$				
45×25	over 170 incl. 200	45	10.4	15.0	$\begin{smallmatrix} 0 \\ -0.3 \end{smallmatrix}$				
50×28	over 200 incl. 230	50	11.4	17.0	$\begin{smallmatrix} 0 \\ -0.3 \end{smallmatrix}$				
56×32	over 230 incl. 260	56	12.4	20.0	$\begin{smallmatrix} 0 \\ -0.3 \end{smallmatrix}$				
63×32	over 260 incl. 290	63	12.4	20.0	$\begin{smallmatrix} 0 \\ -0.3 \end{smallmatrix}$				
70×36	over 290 incl. 330	70	14.4	22.0	$\begin{smallmatrix} 0 \\ -0.3 \end{smallmatrix}$				

**Notes:**

1. Use ISO R773 (DIN6885.1) parallel key, and DIN6885.3 parallel key for models marked \* at bore size on page 3.
2. Key way tolerance does not comply with DIN6885 of BR-HT.

## Recommended End Plate Dimension Table

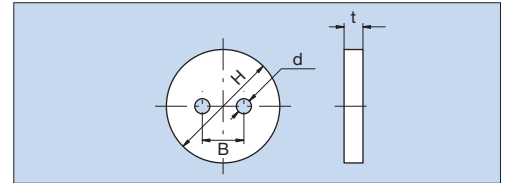

Bore Size	End Plate dimension				
	H	t	d	B	Bolt Size
20	30	5	6	10	M5
25	37	5	6	10	M5
30	42	5	6	15	M5
35, 40	55	6	7	18	M6
45, 50	65	6	7	25	M6
55, 60	75	6	7	30	M6
65, 70	85	6	9.5	40	M8
75, 80	95	6	9.5	50	M8
85, 90	110	9	11.5	60	M10
95, 100	120	9	11.5	70	M10
Over 100 incl. 120	140	9	11.5	70	M10
Over 120 incl. 140	166	9	11.5	80	M10
Over 140 incl. 160	190	10	14.5	100	M12
Over 160 incl. 190	225	10	14.5	120	M12
Over 190 incl. 220	255	10	14.5	140	M12
Over 220 incl. 250	290	14	18.5	170	M16
Over 250 incl. 280	320	14	18.5	200	M16
Over 280 incl. 320	365	14	18.5	230	M16

**Note:** End plate shall be supplied by customer.

# TSUBAKI EMERSON CAM CLUTCHES



Tsubaki offers various series of cam clutches to meet any industrial demand. Excluding the series mentioned in this brochure you may need additional technical solutions to comply with your specific application. Please do not hesitate to contact us for advice or further information. Our well trained professional engineers and sales staff are ready to provide further assistance.



## WARNING

### USE CARE TO PREVENT INJURY.

#### COMPLY WITH THE FOLLOWING TO AVOID SERIOUS PERSONAL INJURY.

1. Guards must be provided on all power transmission and conveyor applications in accordance with provisions of ANSI/ASME B 15.1 1992 and ANSI/ASME B 20.1 1993 or other applicable standards. When revisions of these standards are published, the updated edition shall apply.
2. Always lock out power switch before installing, removing, lubricating or servicing a system that uses Cam Clutch products.
3. If the Cam Clutch is used for repeated starting and stopping, make sure the strength of the supports for the Cam Clutch are sufficient.
4. The capacity of your Cam Clutch may be effected by the accuracy of its set up, the amount of pressure exerted on it, wear on other parts in your system, or wear life of the Cam Clutch itself. Check the Cam Clutch at regular intervals and take any necessary safety precautions.
5. When connecting or disconnecting Cam Clutch products, eye protection is required. Wear safety glasses, protective clothing, gloves and safety shoes.



## TSUBAKI EMERSON CO.

1-1, Kotari-Kuresumi, Nagaokakyo, Kyoto 617-0833, Japan  
<http://www.tsubaki-emerson.co.jp/>

Tel: +81-75-957-3131  
 Fax: +81-75-957-3122

#### Group Companies:

#### NORTH and SOUTH AMERICA

**U.S. TSUBAKI, INC.**  
 301 E. Marquardt Drive,  
 Wheeling, IL 60090-6497  
 U.S.A.  
 Tel: +1-847-459-9500  
 Fax: +1-847-459-9515

**TSUBAKI of CANADA LIMITED**  
 1630 Drew Road, Mississauga, Ontario,  
 L5S 1J6  
 Canada  
 Tel: +1-905-676-0400  
 Fax: +1-905-676-0904

**TSUBAKI BRASIL EQUIPAMENTOS  
 INDUSTRIAIS LTDA.**  
 Rua Pamplona, 1018, C.J. 73/74, Jardim  
 Paulista, CEP 01405-001, São Paulo, S.P.  
 Brazil  
 Tel: +55-11-3253-5656  
 Fax: +55-11-3253-3384

#### EUROPE

**TSUBAKIMOTO EUROPE B.V.**  
 Aventurijn 1200, 3316 LB Dordrecht  
 The Netherlands  
 Tel: +31-078-6204000  
 Fax: +31-078-6204001

**TSUBAKIMOTO U.K. LTD.**  
 Sherwood Park, Annesley, Nottingham,  
 NG150DX, United Kingdom  
 Tel: +44-01623-688700  
 Fax: +44-01623-688789

**TSUBAKI DEUTSCHLAND GMBH**  
 ASTO Park Oberpfaffenhofen  
 Friedrichshafener Straße 1  
 D-82205, Gilching  
 Germany  
 Tel: +49-8105 730 7100  
 Fax: +49-8105 730 7101

#### ASIA and OCEANIA

**TSUBAKIMOTO SINGAPORE PTE. LTD.**  
 25 Gul Lane, Jurong  
 Singapore 629419  
 Tel: +65-6861-0422  
 Fax: +65-6861-7035

**TSUBAKI INDIA POWER  
 TRANSMISSION PRIVATE LIMITED**  
 Chandrika Chambers No.4, 3rd Floor,  
 Anthony Street, Royapettah, Chennai,  
 Tamil Nadu 600014 India  
 Tel: +91-44-4231-5251  
 Fax: +91-44-4231-5253

**TSUBAKIMOTO (THAILAND) CO., LTD.**  
 999/9 The Offices at Centralworld,  
 10th Floor, No. 1001, Rama 1 Road,  
 Pathumwan, Bangkok 10330 Thailand  
 Tel: +66-02-264-5354  
 Fax: +66-02-251-3912

**TSUBAKI AUSTRALIA PTY. LIMITED**  
 Unit E, 95-101 Silverwater Road,  
 Silverwater, N.S.W. 2128  
 Australia  
 Tel: +61-02-9704-2500  
 Fax: +61-02-9704-2550

**TAIWAN TSUBAKIMOTO CO.**  
 No. 33, Lane 17, Zhiciang N. Rd.,  
 Gueishan Township, Taoyuan County  
 Taiwan R.O.C.  
 Tel: +886-33-293827/8/9  
 Fax: +886-33-293065

**KOREA CONVEYOR IND. CO., LTD**  
 68B 7L, Namdong Industrial Estate,  
 627-3, Gojan-dong, Namdong-gu,  
 Incheon Republic of Korea  
 Tel: +82-32-817-0160  
 Fax: +82-32-819-9168

**TSUBAKI EMERSON MACHINERY (SHANGHAI) CO., LTD.**  
 No. 5 Building, No. 1151 Xingxian Rd.,  
 Jiading Industrial North Area, Shanghai 201815  
 People's Republic of China  
 Tel: +86-021-3953-8188  
 Fax: +86-021-6916-9308

#### Distributed by: